

WS1" Series Tannex Unit

Installation Operation Maintenance Manual

Installation Operation Maintenance Manual



Simplex Tannex Units With WS1"Series Valve

Models 20 ltr - 250 ltr

WS1” Series Tannex Unit

Installation Operation Maintenance Manual

1.0 PARTS LIST	3
1.1 BASIC PARTS LIST	3
1.2 MISSING OR DAMAGED GOODS	3
2.0 TEMPORARY STORAGE	3
3.0 REGENERATION	3
3.1 The Regeneration Process	3
3.2 METER CONTROL OF REGENERATION	4
3.3 TIME CLOCK CONTROL OF REGENERATION INITIATION	4
4.0 PRE-INSTALLATION CHECKS	4
4.1 MECHANICAL	4
4.1.1 Foundation/Drainage	4
4.1.2 Operating Space	5
4.1.3 Incoming Water	5
4.1.4 Pipework	5
4.1.5 Water Supply Company Requirements	5
4.2 ELECTRICAL	6
5.0 ASSEMBLY/INSTALLATION	6
5.1 MECHANICAL	6
5.1.1 Pipework	6
5.1.2 Assembly	6
5.2 Options	7
5.2.1 No Hard Water Bypass	7
5.2.2 Differential Pressure Switch (dP)	8
6.0 PROGRAMMING	8
6.1 INTRODUCTION	8
6.2 CONTROLLER SETTING	8
6.2.1 Setting the Time of Day	9
6.3 Factory Programming	10
7.0 COMMISSIONING	13
8.0 ROUTINE MONITORING	14
9.0 FAULT FINDING AND RECTIFICATION	15
9.1 NO FLOW TO SERVICE	15
9.2 POOR TREATED WATER QUALITY	15
9.3 NO REGENERATION	16
9.4 UNSATISFACTORY CAPACITY BETWEEN REGENERATIONS	16
10.0 WARRANTY AND SERVICE	16
10.1 AFTER SALE WARRANTY	16
11.0 Technical Data	17
11.1 Process and Operating Data	17
11.1.1 WS1 20-80 L	17
11.1.2 WS1 100-250 L	18
11.2 ENGINEERING DATA	19
11.2.1 WS1 20-80 L	19
11.2.2 WS1 100-250 L	20
12.0 FACTORY PROGRAM	21
13.0 CE Certificate	23

WS1” Series Tannex Unit

Installation Operation Maintenance Manual

1.0 PARTS LIST

1.1 BASIC PARTS LIST

1. WS1 VALVE C/W TRANSFORMER
2. VESSEL & RISER
3. BRINE TANK
4. INSTRUCTIONS
5. REDUCER (if required)
6. RESIN

1.2 MISSING OR DAMAGED GOODS

Immediately on receipt of the goods, it is advisable to check that all items ordered have been received. If you have any doubt that goods have been supplied as requested, please contact your supplier immediately. If any items are missing or damaged, the carrier and your supplier must be notified within 2 days of receipt if a claim is to be made.

2.0 TEMPORARY STORAGE

If installation is not to start immediately after delivery, the equipment should be stored in a clean dry area, where it will not be damaged, or be subjected to temperatures below freezing.

3.0 REGENERATION

3.1 *The Regeneration Process*

The regeneration process consists of six stages:-

1. Backwash - Water flows upwards through the resin bed, and out to a drain. As it does so, it loosens the ion exchange beads, removes any resin 'fines' (i.e. small pieces of broken beads etc.) and cleans off any particles of dirt or pipework corrosion products which may have accumulated during the service cycle.

2/3. Brine/Slow Rinse - During the first part of this stage, the concentrated salt -solution is drawn from the brine tank, blended with water to reduce the concentration to the correct level, and passed down through the resin. When the required quantity of brine has been drawn in, the water flows alone to push the remaining brine through the resin at the correct rate, and ensure that all of the resin sees the right amount of regenerant.

WS1” Series Tannex Unit

Installation Operation Maintenance Manual

4. Backwash (2nd) - This valve has the unique facility of performing a second backwash allowing for optimum regeneration, efficiency and cleaning of the resin bed. Water flows as in the first backwash cycle.

5. Fast Rinse - This follows the brine and slow rinse cycle, and entails rinsing away the residual brine and Calcium and Magnesium salts from the resin and re-packing the resin bed. This is carried out down flow with water flowing through the resin in the direction of service.

6. Salt Tank Refill - Following the fast rinse, a quantity of water sufficient to dissolve the correct amount of salt for the next regeneration is returned to the salt tank. When this has finished, the unit automatically returns to service.

3.2 METER CONTROL OF REGENERATION

On meter controlled valves a water meter is installed in the outlet from the softener, to measure the volume of water which passes to service. The internal turbine rotates with the flow of water and reports its rate of rotation through Hall-effect circuitry to the printed circuit board. When the reading reaches zero the valve will automatically regenerate that night at 2 am for delayed regeneration softeners or immediately for immediate regeneration softeners.

3.3 TIME CLOCK CONTROL OF REGENERATION INITIATION

Time clock configuration valves initiate regeneration at a pre-set time after a pre-set number of days. The frequency of regenerations are adjustable on programming the timer (Regeneration control).

4.0 PRE-INSTALLATION CHECKS

4.1 MECHANICAL

4.1.1 Foundation/Drainage

The softener will not require any special foundations, provided that a firm, level area which is capable of supporting the working weight is available. (See Engineering Data, Section 11.2)

Unwanted water from the regeneration process must flow to drain, and so an open drain or gully, capable of passing the necessary flow is required (see Process and Operating Data, 11.1, for relevant flows). The total flow of water to drain depends on site conditions, but will be approximately 6 times the resin volume. Preferably the drain should be level with or no higher than 500mm above the softener valve.

A second drain is required for the brine tank overflow. This is a safety drain which will only discharge water if there is a malfunction in the control

WS1” Series Tannex Unit

Installation Operation Maintenance Manual

valve. Where possible this should be installed through an outside wall like a cistern overflow, where it will give a visual indication of any failure.

4.1.2 Operating Space

The space occupied by the softener can be found in the Engineering Data (Section 11.2).

Access will be required to refill the salt tank, and to carry out adjustments or maintenance on the equipment. It is therefore recommended that a minimum of 500mm clearance be allowed in front of the unit for this purpose.

4.1.3 Incoming Water

The raw water to be fed to the softener must comply with the following:-

1. Available at all times at a flow equal to or greater than the required service flow
2. At a pressure between 1.7 and 8.0 bar
3. Temperature between 4 and 38°C
4. Suspended solids less than 1 ppm
5. Iron less than 0.2 ppm, Manganese less than 0.1 ppm, Free Chlorine less than 1 ppm if temperature is less than 15°C, less than 0.3 ppm if temperature higher (up to 30°C)

4.1.4 Pipework

Pipework to be connected to the softener should not have an excessive amount of hardness scale deposit. Piping that is heavily built up with scale (or Iron deposits) should be replaced.

Make sure that the pipework can be connected to the softener in such a way as to impose no stresses on the control valve, and that it is properly aligned and supported.

A system for the complete by-passing and isolation of the softener should be installed.

4.1.5 Water Supply Company Requirements

It is essential that if the equipment is to be connected directly to a mains water supply, the local bylaws must be adhered to. These cover both plumbing and the prevention of backflow into the mains. If there is any doubt, the local water inspector should be consulted, but in general, the installation of a 'Double check valve assembly' conforming to BS6282 part 2 will be required in the feed pipework to the softener.

If the pressure available from the mains is not adequate it will be necessary to install a booster pump arrangement. Such a system would

WS1” Series Tannex Unit

Installation Operation Maintenance Manual

be covered by additional bylaws, and the water storage tank needed must comply with these.

4.2 ELECTRICAL

A continuous supply of 240v, 5 VA is required. The softener itself is 12 volt but a plug in 240v/12v transformer is supplied and should be connected to an uninterrupted mains supply, which is separately 1 Amp fused, and does not have any additional switch.

5.0 ASSEMBLY/INSTALLATION

5.1 MECHANICAL

Check all the items against the parts list and shipping documents, and ensure you have them all before starting work. In addition to the softener you will require installation materials and basic tools, (i.e., spanners, screwdrivers etc., and PTFE tape)

5.1.1 Pipework

Pipework should be assembled incorporating the features shown in the Installation Diagram, Section 14.1. It is essential that inlet and outlet isolating valves and a by-pass valve are provided, and that the water main is protected by a double check valve where appropriate (see Local Water Bye-laws).

Pipework can be constructed from any normally acceptable material (Copper, Galvanised, Plastic), provided it is properly supported and aligned. Ensure that the pipe is sufficiently large to accommodate the flow of water required, making due allowance for the pressure drop between the softener and the point of discharge of soft water.

NOTE: IF BRAZED OR SOLDERED FITTINGS ARE TO BE USED, THE PIPE WORK MUST BE DISCONNECTED FROM THE VALVE DURING HEATING AND COOLING. EXCESS HEAT CAN CAUSE PERMANENT DAMAGE TO SOME OF THE VALVE COMPONENTS.

5.1.2 Assembly

If possible place the pressure vessel on its final location before filling. Check that the distributor tube, with its yellow top cover, is in place and using a funnel slowly pour in the resin taking care not to spill any on the floor. Ensure that the distributor tube remains central in the vessel during filling. After emptying all the bags, the vessel should be almost 75-80% full. This is to allow for the rising of the resin bed during backwash. Once the vessel is filled, immediately sweep up any spilled resin.

WS1" Series Tannex Unit

Installation Operation Maintenance Manual

Remove cover from distributor tube and brush any beads of resin out of the threads in the neck of the vessel.

Unpack valve and skip down over the distributor tube. Screw the valve in to the resin vessel, taking care not to cross the threads. Excessive force should not be needed as the valve is running in to the vessel. Finally tighten to approximately 20 ft/lbs torque. Adjust position of vessel to line up pipework connections, not the position of the valve on the vessel.

Position the brine tank and connect brine line to the bulkhead connector above the overflow (3/8"). Ensure that a brass insert is placed inside the brine line before connecting.

Connect inlet and outlet pipework to the valve (1" BSP 90 deg or straight male threaded elbows at rear of valve) using flexibles where possible or rigid high pressure pipe and socket unions. Some flexible pipework is advisable to prevent stress on the vessel as it cycles during service, since it will expand and contract longitudinally.

Connect drain line to the drain outlet (3/4" male threaded elbow on top of valve). Ensure that there is an air break in the drain line at the same height as the valves to prevent negative pressure on the vessel.

Connect brine line to the brine connection on the valve. Again ensure that a brass insert is placed inside the brine line before connecting.

Connect power supply to valve and commission.

5.2 Options

5.2.1 No Hard Water Bypass

All Clack valves are fitted with Bypass pistons, they will pass regeneration water to service if there is a demand during regeneration. If this is a potential problem then it can be resolved by fitting a Motorised Alterating Valve (MAV) with one port block or a No Hard Water Bypass Valve (NHWBV) on the outlet of the valve. The two pin connector from the MAV or NHWBV has to be connected to the ALTERNATOR DRIVE pin of the Clack valve and step 3CS in the OEM programming level has to be set to nHbP. The MAV or NHWBV will be driven to close before the first regeneration cycle that is not FILL or SOFTENING or FILTERING and be driven open after the last regeneration cycle that is not FILL.

WS1” Series Tannex Unit

Installation Operation Maintenance Manual

5.2.2 Differential Pressure Switch (dP)

There is a dP input on Clack valves that can be used to carry out the following functions depending upon the setting of step 4CS in the OEM programming level

- 4CS set to OFF no function
- 4CS set to dPon0 if the dp switch is closed for an accumulative time of 2 minutes a regeneration will occur immediately
- 4CS set to dPdEL if the dp switch is closed for an accumulative time of 2 minutes a regeneration will occur at the scheduled regeneration time
- 4CS set to HoLD if the dp switch is closed a regeneration will be preventing from occurring.

6.0 PROGRAMMING

6.1 INTRODUCTION

It is recommended that the commissioning of the plant is undertaken by a trained service engineer, who will be able to put the plant into service quickly, and most efficiently. However, if the services of an experienced engineer are not available, following the steps outlined below will result in the system being properly commissioned.

6.2 CONTROLLER SETTING - Site programming mode

All controller settings will require the valve to have the mains supply switched on. The valve must not be regenerating when controller settings are adjusted.

WS1” Series Tannex Unit

Installation Operation Maintenance Manual

6.2.1 Setting the Time of Day

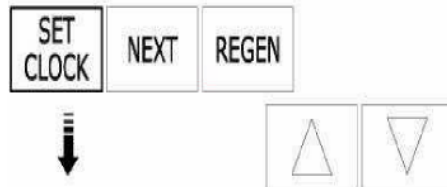

The softener regeneration cycles have been factory programmed. On metered softeners the volume capacity of the resin in litres has also been

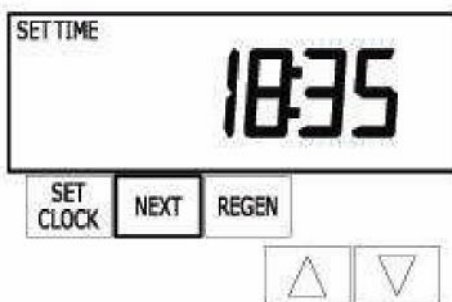

1. Press SET CLOCK
2. Adjust hours with UP and DOWN arrows
3. Press NEXT

4. Adjust minutes with UP and DOWN arrows.
5. Press NEXT to return to normal operation

entered on a default hardness of 300ppm and a reserve capacity of 33%. This may need to be altered based on local water hardness and reserve required for the site (see section 13.1) The time of day for

WS1” Series Tannex Unit

Installation Operation Maintenance Manual

regeneration has been entered as 2 AM, this can be changed if necessary.

6.3 Factory Programming

Regeneration Programming

(All programming below is Factory set)

To alter settings – Press “↑” and “↓” keys
To back up at any stage – Press “REGEN”
To save any changes – Press “SET CLOCK”

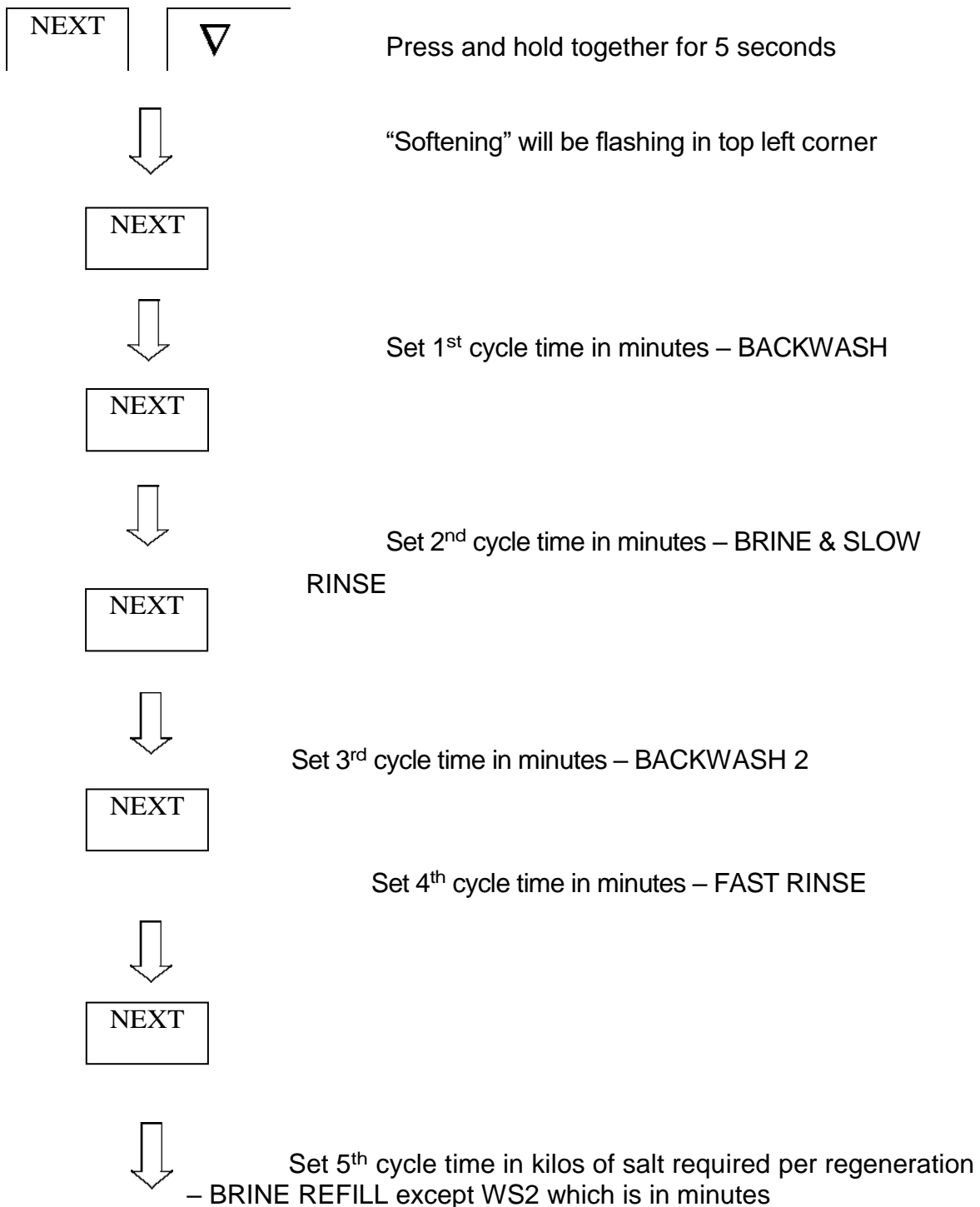

WS1” Series Tannex Unit

Installation Operation Maintenance Manual

NEXT



Capacity in Kilograms-Set according to Softener Size in Technical data if metered, ignore if timeclock

NEXT



Set Auto if metered, off if timeclock

NEXT



Set type of regeneration required:-
“NORMAL” – Delayed Regeneration
“on 0” – Immediate Regeneration “NORMAL + on 0” –
Either Delayed or Immediate Regeneration, whichever occurs first

NEXT



Set Salt to Off

NEXT

Programming Finished – Return to time of day

User Programming

To alter settings – Press “↑” and “↓” keys To back up at any stage – Press “REGEN” To save any changes – Press “SET CLOCK”

Press together and hold for 5 seconds

NEXT

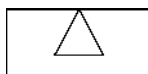

Set Influent Hardness in ppm if metered, nA if timeclock



WS1 Series Tannex Unit

Installation Operation Maintenance Manual

NEXT

Set effluent hardness in ppm if mixing valve fitted, if no mixing valve fitted then set to 0 if metered. NA if timeclock.



NEXT

Set day regeneration override for metered softeners OR set frequency of regenerations for Timeclock valves (1-28 days)



NEXT

Set time for regeneration hours. Time for Immediate regeneration valves cannot be altered and will show "on 0"



NEXT

Returns to time of day

WS1 Series Tannex Unit

Installation Operation Maintenance Manual

7.0 COMMISSIONING

The objective of commissioning is to fill the softener and brine tank with water, check for leaks and prepare it for service. The simplest way to commission the unit is to initiate a regeneration. This will eliminate the air from the system and flush the resin prior to use.

Manually add water to the brine tank until it is filled approximately 6" (100mm) from the bottom of the tank.

Before opening the inlet water supply, ensure that the outlet is shut and switch on the power supply and press the "REGEN" button on the valve. "Regen today" will appear at the bottom left of the timer, by continuing to press the "REGEN" button the motor will power up and move the valve into the backwash position. Slowly open the inlet valve. At first, air will be expelled from the drain line, followed by water once the vessel is full. The first quantity of water will have a tan colouration which is perfectly normal. Allow water to run to drain until the water is clear.

Next, press the "Regen" button and the motor will move the valve into the brine and slow rinse position. Ensure that the water level in the brine tank drops as water is drawn in. During brine and slow rinse water will slowly run to drain.

Press the "Regen" button 3 more times (after pressing the button once, wait for the motor to stop before pressing it again) until the valve reaches the refill stage. Ensure that water is now refilling the brine tank. Leave to fill for full duration of the cycle and add salt to the brine tank. The level the water will reach depends on the type of salt used and the resin volume of the softener

At the end of the refill cycle the motor will automatically move the valve back into the service position. The softener is now commissioned. Open the outlet from the softener to run water to service.

Add salt to the brine tank. If tablet salt is used (recommended) then the cabinet can be filled to the top. If granular salt is used then the cabinet must only be 3/4 full.

WS1 Series Tannex Unit

Installation Operation Maintenance Manual

8.0 ROUTINE MONITORING

The following recommendations are made to help the user of the softener confirm that it is performing as required, and to give early warning of possible problems. The operation of the softener is completely automatic, and should not require adjustment.

Weekly

Check the treated water hardness with a hardness test kit.
Inspect the level of salt in the salt tank and refill if necessary.

Monthly

Check raw water hardness, and record. Compare with original hardness and adjust volume capacity setting if required (see Section 12.0).

Annually

Inspect and clean/replace as necessary the brine injector, brine screen and the internal disc/flapper set. This should be performed by a competent engineer familiar with the WS1 valve.

WS1 Series Tannex Unit

Installation Operation Maintenance Manual

9.0 FAULT FINDING AND RECTIFICATION

Modern Tannex Units are extremely reliable and unlikely to give any problems if they are installed and operated correctly.

9.1 NO FLOW TO SERVICE

Check mains pressure is above 1.7 bar.

Check inlet and outlet isolating valves are open.

Check service outlet valve is open.

Check pressure drop across resin. If excessive, resin may be fouled, or internals blocked. Initiate a regeneration. If this does not free up the resin the softener will need to be inspected and serviced by a competent engineer.

9.2 POOR TREATED WATER QUALITY

Check manual by-pass closed.

Check salt level in salt tank. Refill if necessary.

Trickle flow through conventional ball valve in storage tank. Replace with Torbeck or Fluidmaster servo valve.

Check raw water pressure above minimum. If flow is less than minimum, channelling of water can occur in resin. which results in inadequate treatment.

Check injector strainer and injector not blocked (see Appendix for drawings). Clean if necessary.

Check brine pick-up screen not blocked. Clean if necessary.

Check brine line not split. Replace if necessary.

WS1 Series Tannex Unit

Installation Operation Maintenance Manual

9.3 NO REGENERATION

Check electrical supply, fuses etc. satisfactory.

Check control head motor runs by initiating a manual regeneration (Press "REGEN" button for 5s and then again for a further 5s), listening for drive motor 'whirring' as it advances between cycles. Replace if necessary.

Check internal meter running freely (if fitted) indicated by small black dot in center of display flashing.

9.4 UNSATISFACTORY CAPACITY BETWEEN REGENERATIONS

Check condition of resin. It may have become fouled, inhibiting the regeneration process. If fouled, it should be cleaned or replaced.

Check incoming water for presence of Chlorine. If high, the resin may have been degraded.

Check raw water pressure. Too high pressure may mean the brine draw stage of regeneration is not effective

10.0 WARRANTY AND SERVICE

10.1 AFTER SALE WARRANTY

Your softener is covered by a parts warranty for a period of one year from installation or 14 months from purchase.

Should you have any problems with your softener or require a routine service, please contact your supplier.

WS1 Series Tannex Unit

Installation Operation Maintenance Manual

11.0 Technical Data

11.1 Process and Operating Data

11.1.1 WS1 20-80 L

PARAMETER	UNITS	25L	30L	40L	50L	60L	80L
MAX.SERVICE FLOW	M3/hr	1	1.2	1.6	2	2.4	3.2
SALT USED PER REGEN	Kg	6.25	7.5	10	12.5	15	20
REGENERATION TIME	MIN	48	68	72	72	72	72
SALT STORAGE CAPACITY	Kg	120	120	120	160	300	300
MAX OPERATING TEMP	°C	50	50	50	50	50	50
MAX FLOW TO DRAIN	LIT/MIN	5.7	9	9	9	15.14	15.14

IMPORTANT NOTES

Much of the data quoted in the above table is affected by the inlet pressure, and so should be regarded as nominal only.

Total flow to drain will be similarly affected and is therefore not quoted, but will be about 6 times the resin volume.

WS1 Series Tannex Unit

Installation Operation Maintenance Manual

11.1.2 WS1 100-250 L

PARAMETER	UNITS	100L	120L	150L	250L
MAX.SERVICE FLOW	M3/hr	4	4.3	6	6
SALT USED PER REGEN	Kg	25	30	37.5	62.5
REGENERATION TIME	MIN	96	96	96	120
SALT STORAGE CAPACITY	Kg	300	300	300	400
MAX OPERATING TEMP	°C	50	50	50	50
MAX FLOW TO DRAIN	LIT/MIN	19	19	26	37

IMPORTANT NOTES

Much of the data quoted in the above table is affected by the inlet pressure, and so should be regarded as nominal only.

Total flow to drain will be similarly affected and is therefore not quoted, but will be about 6 times the resin volume.

WS1 Series Tannex Unit

Installation Operation Maintenance Manual

11.2 ENGINEERING DATA

11.2.1 WS1 20-80 L

PARAMETER	UNITS	25L	30L	40L	50L	60L	80L
VESSEL SIZE	INCH	9x35	10x35	10x44	10x54	12x48	13x54
BRINE TANK HEIGHT	MM	960	960	960	1040	1040	1040
BRINE TANK WIDTH	MM	370x 430	370x 430	370x 430	480	480	480
TOTAL HEIGHT	MM	1100	1100	1340	1590	1440	1590
REAR CLEARANCE REQUIRED	MM	50	50	50	50	50	50
INLET CONNS	INCH	1	1	1	1	1	1
OUTLET CONNS	INCH	1	1	1	1	1	1
DRAIN CONNS	INCH	$\frac{3}{4}$	$\frac{3}{4}$	$\frac{3}{4}$	$\frac{3}{4}$	$\frac{3}{4}$	$\frac{3}{4}$
BRINE TANK OVERFLOW	INCH	$\frac{1}{2}$	$\frac{1}{2}$	$\frac{1}{2}$	$\frac{1}{2}$	$\frac{1}{2}$	$\frac{1}{2}$
DELIVERED WEIGHT	KG	19	20	21	23	25	30
ELECTRICAL POWER 240 V 50 HZ	V/A	1.2	1.2	1.2	1.2	1.2	1.2

IMPORTANT NOTES

MAXIMUM OPERATING PRESSURE 5.5 BARG MINIMUM OPERATING PRESSURE 1.7 BARG
HEADROOM ALLOW 100MM GREATER THAN THE OVERALL HEIGHT.

WS1 Series Tannex Unit

Installation Operation Maintenance Manual

11.2.2 WS1 100-250 L

PARAMETER	UNITS	100L	120L	150L	250L
VESSEL SIZE	INCH	14x65	14x65	16x65	21x62
BRINE TANK HEIGHT	MM	950	950	950	900
BRINE TANK WIDTH	MM	840	840	700	840
TOTAL HEIGHT	MM	1984	1984	1988	2038
REAR CLEARANCE REQUIRED	MM	50	50	50	50
INLET CONNS	INCH	1	1	1	1
OUTLET CONNS	INCH	1	1	1	1
DRAIN CONNS	INCH	$\frac{3}{4}$	$\frac{3}{4}$	$\frac{3}{4}$	$\frac{3}{4}$
BRINE TANK OVERFLOW	INCH	$\frac{1}{2}$	$\frac{1}{2}$	$\frac{1}{2}$	$\frac{1}{2}$
DELIVERED WEIGHT	KG	115	130	170	280
ELECTRICAL POWER 240 V 50 HZ	V/A	1.2	1.2	1.2	1.2

IMPORTANT NOTES

MAXIMUM OPERATING PRESSURE 5.5 BARG MINIMUM OPERATING PRESSURE 1.7 BARG
HEADROOM ALLOW 100MM GREATER THAN THE OVERALL HEIGHT.

WS1 Series Tannex Unit

Installation Operation Maintenance Manual

12.0 FACTORY PROGRAM

To enter press Next and down for 5 seconds

Screen	Entered Value	Explanation
	Softening	Softening Valve
1 Backwash	25 4 30 4 50 6 75 6 100 8 120 8 150 8 250 10	Backwash time against resin volumes
2 Brine	25 40 30 60 50 60 75 60 100 80 120 80 150 80 250 100	Brine draw slow rinse against resin volumes
3 Backwash	4	Second Backwash time
4 Rinse	25 4 30 4 50 6 75 6 100 8 120 8 150 8 250 10	Fast Rinse time against resin volumes
5 Fill	25 6.25 30 7.2 50 12.5 75 18.75 100 25 120 30 150 37.5 250 62.5 Salt Saturator 1	When softener is connected to a Salt Saturator then a refill time of 1 minute and the smallest brine refill button is used
Capacity	Ignore	Resin Capacity this is used with the hardness input to give capacity in m3
Regen	Off	Timeclock based

WS1 Series Tannex Unit

Installation Operation Maintenance Manual

rLY 1	Off	
rLY 2	Off	
SALT	Off	N/A

WS1 Series Tannex Unit

Installation Operation Maintenance Manual

13.0 CE Certificate

Manufacturer's Declaration of Conformity

We the undersigned

EURAQUA UK, HITCHIN, ENGLAND

Certify that the product

type: SIMPLEX TANNEX UNIT WITH CLACK WS1" 12 VOLT AC VALVE

has been designed and manufactured in accordance with the specifications of the following:

Directive Standard

The Electromagnetic Compatibility Directive 2004/108/EC

and

The Low Voltage Directive (Electrical Safety) 2006/95/EC

and

The Machinery Directive 2006/42/EC

A Morlidge

Director

Hitchin, England 30/01/19

Issue place & date

